



gemini
ITALY

**Personal Ionic HEPA
filtration Air Purifier**
**個人負離子HEPA過濾
空氣淨化機**

MODEL NO.: GAP5B

3W



A GILMAN GROUP BRAND

Please read and retain for future reference.

SAFETY INSTRUCTION - GENERAL

- Use this appliance solely in accordance with these instructions.
- This appliance is for household use only, not for commercial purpose.
- Remove all packaging material from the appliance before use.
- This appliance shall not be used by children of 0 to 8-year old.
- This appliance can be used by children older than 8-year old and persons with reduced physical, sensory or mental capabilities or lack of experience and knowledge, but only if they have been given supervision or instruction concerning use of the appliance in safe way and understand the hazards involved.
- Children should be supervised to ensure that they do not play with the appliance.
- Cleaning and maintenance must not be done by children.
- Have any repairs carried out solely by a qualified electrician. Never try to repair the appliance yourself.
- Do not handle the plug or appliance with wet hands.
- Do not immerse the main body in water.
- Children shall not play with the appliance.
- Do not leave the appliance unattended when connected to the mains supply.
- Only use the attachments/accessories supplied with the product.

SAFETY INSTRUCTION - ELECTRICITY AND HEAT

- Ensure the appliance is placed on a horizontal, even and stable surface.
- Verify that the mains voltage is the same as that indicated on the rating plate on the appliance before use.
- Never use the extension cord as power connection.
- Make sure that the appliance, the USB cable do not make contact with water.
- Make sure that the appliance, the USB cable do not make contact with hot surface, such as a hot hob or naked flame.
- Check the appliance's USB cable regularly to make sure it is not damaged.
- Do not use the appliance if the USB cable is damaged. If the USB cable is damaged in order to avoid any hazards.
- Never use the appliance in the vicinity of flammable material.

SAFETY INSTRUCTION – DURING OPERATION

- Do not pick up the appliance if falls into water. Remove the plug from the socket immediately. Do not use the appliance again.
- Never immerse the appliance, the power cord or the plug in water or any liquid.
- Do not move the appliance while its switched on.
- Do not use the liquids, such as water or flammable solvents to clean the product, please use a soft cloth to clean when product not in running.
- Please keep air circulation and do not cover detect air quality sensor, air inlet and outlet when the product is running.
- Please close the car and room window when product running to improve the purification, and please adjust to lowest air-conditioning power when you turn on the air-conditioner.
- To keep safety, please DO NOT open the product top cover when it is running.
- Please install the purifier firmly on the car cup holder, and prohibit to place it on the car dashboard to avoid any accidents.
- For your safety, DO NOT adjust the product when driving.
- Do not use other type power adapters, keep use the original accessories which accompany with the package.
- Please refer to "Cleaning and Maintenance" section to clean the appliance.

PRODUCT OVERVIEW

- 1.Gradient LED lights (Decoration purpose)
(Red/ yellow/ blue/ green/ white/
orange/ purple)
- 2.Air outlet
- 3.Main body
- 4.LED touch panel & display screen
- 5.Air inlet
- 6.Detect air quality sensor
- 7.USB cable (1.5 metre)

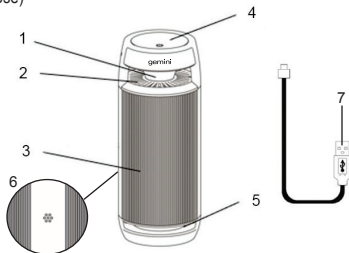

Filter

(Pre-filter, HEPA filter & Activated carbon filter)

LED Display Screen

- 1.The purification wind speed indication
 - 1a.Primary purification (low speed 🌀)
 - 1b.Rapid purification (medium speed 🌀)
 - 1c.High-efficiency purification (high speed 🌀)
 - 1d.Automastic mode 🌀
- 2.Temperature indicator
- 3.Humidity indicator
- 4.Air quality indicator (blue/ yellow/ red)
- 5.On/ Off / Purification wind speeds button
(LOW-MED-HIGH, Automatic mode
can not be selected manually)
- 6.Current room temperature display
- 7.Current room humidity display

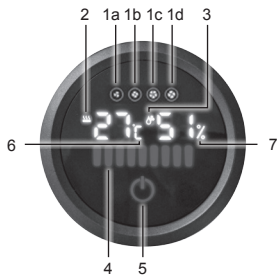

HOW TO USE

- Connect the power source (5V) to the product with the provided USB cable.

- **Automatic mode on touch panel:**

Connect to the power source, the product will turn on automatically and enters into the automatic mode if there is no input operation by user in 2 seconds. The On/ Off/ Purification wind speeds button  remains blue at the beginning. The appliance will detect automatically based on detect air quality sensor to adjust suitable purification wind speeds (LOW–MED–HIGH) around 2 minutes.

Blue light-> Good air quality

Yellow light-> Poor air quality

Red light -> Bad air quality

If good air quality, the purification speed starts at LOW. (LOW  & AUTO )

If poor air quality, the purification speed starts at MED. (MED  & AUTO )



If bad air quality, the purification speed starts at HIGH. (HIGH  & AUTO )

*This automatic mode cannot select on touch panel by manual. The purifier will detect the air quality when connect to the power supply under this mode.

- **Manually Mode on touch panel:**

Connect to the power source, touch the On/ Off / Purification wind speed button  to adjust the 3 purification speeds.

Touch  once: Turn on Primary purification (low speed )

Touch  twice: Turn on Rapid purification (medium speed )



Touch  three times: Turn on High-efficient purification (high speed ), as a cycle

Press it and hold about 3 seconds, product will turn-off.

- **How to turn on and off the gradient LED lights:**

When connect the power source, the decoration LED lights will be automatically turned on. When touching the On/ Off / Purification wind speeds button  around 2 seconds, the lights will turn off. Need restart the appliance to turn on the LED lights again.

FILTER REPLACEMENT

In order to keep the best purify performance, we suggest it is better to replace the filter after 3-5 months of use. If need to replace filter, the On/ Off/ Purification wind speeds button  will automatically warning as red light flicker 3 times and 3 "Dee" sounds during operation. After replace filter, press and hold the On/ Off/ Purification wind speeds button  for 8 seconds to start resetting till the green light flicker will start, then it will reset and start to work normally.

Shutdown the power first, then rotate the bottom casing of the machine at clockwise direction, and then loosen naturally after turning to the position (Fig.1). Take out the filter in the middle, and then replace in a new one (Fig.2). Rotate the base at counter-clockwise direction and twist it into place (Fig.3).

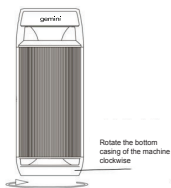

Fig.1

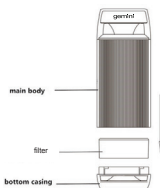

Fig.2

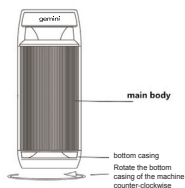



Fig.3

CLEANING AND MAINTENANCE

- Do not use the liquids, such as water or flammable solvents to clean the product, unplug and please use a soft cloth to clean.
- Keep the product at a cool and dry place.

TROUBLESHOOTING

Problem	Cause	Solution
Purifier not works	Did not press On / Off button	Press On / Off button
	Abnormal supply voltage, over/under voltage protection	Check if the supply voltage is 5V
	Power source is disconnected or loose the USB cable	Connect the USB cable / switch on the power source again
The On/ Off/ Purification wind speeds button  warning as red light flicker 3 times and 3 "Dee" sounds	Need to replace filter	Refer to the "FILTER REPLACEMENT" on P.6

PRODUCT SPECIFICATIONS

Model no.: GAP5B

Voltage / Current: DC5V 1A

Power: 3W

Accessory: 1.5 M USB cable

Product dimensions: Ø72 (diameter) × 180 (H) mm

閱讀下列說明事項並請妥善保管，以供日後參考。

安全指引 - 一般安全

- 請按照這些說明事項，使用本產品。
- 本產品僅供家用，不作商業用途。
- 使用前，請將所有包裝材料拆除。
- 0至8歲的兒童不應使用本產品。
- 超過8歲的兒童可使用本產品，但請勿由肢體不健全、感覺或精神上有障礙或缺乏相關經驗和知識的人使用，除非有負責他們安全的人對他們使用本產品進行監督或指導。
- 請務必看顧好兒童，以確保他們不玩耍本產品。
- 兒童不應清潔或維修本產品。
- 當需進行任何維修，必須由專業維修人員進行維修。永遠不要嘗試自己修理本產品。
- 手濕時不可以接觸電源插頭或本機。
- 主機不可以浸入水中。
- 兒童不可以把玩本機。
- 本機開著後不可以無人監管。
- 只使用隨機附送的配件。

安全指引 - 電子和熱能產品

- 請把本產品放置在平穩的表面上使用。
- 使用相符的電源和電壓，以防止觸電。
- 永不可使用延長電線插座於本機上。
- 確保本產品、USB電源線不與水接觸。
- 確保本產品、USB電源線不接觸發熱表面，如明火。
- 定期檢查本產品的USB電源線以確保其沒有損壞。
- 如果USB電源線損壞，請勿使用其產品，以避免出現任何危險。
- 切勿在易燃材料附近使用本產品。

安全指引 - 操作期間

- 如果本產品落入水中，立即從牆身插槽中拔下插頭，並且不要再次使用本產品。
- 切勿將本產品、USB 電源線或插頭浸入水中或其他液體中。
- 當本產品運作時，請勿隨意移動本產品。
- 切勿用液體清洗或潑灑本產品，如水、清洗劑或易燃溶劑等，如需清潔，請將電源斷開，使用柔軟抹布擦拭。
- 請保持本產品周圍空氣暢通無阻，切勿覆蓋本產品的檢測空氣質量傳感器及出入風口。
- 為提高淨化效果，使用本產品時請將車及房間的窗子關閉，如有打開空調，請將空調風力調到最小。
- 為了您的安全，切勿在通電情況下打開機器頂蓋。
- 請將淨化器牢固的安裝到車上，切勿隨意擺放到前方中控臺上，以免造成意外事故。
- 為了您的安全，切勿在駕車時調節本產品，如需調節請先停車。
- 切勿使用不同規格的電源適配器，請使用本產品附帶的配件進行安裝。
- 清潔本產品時請參閱“清潔和保養”部份。

部件示意圖

1. 裝飾的漸變LED燈
(紅/黃/藍/綠/白/橙/紫色持續變色)
2. 出風口
3. 主機
4. LED輕觸顯示屏
5. 進風口
6. 檢測空氣質量傳感器
7. USB充電線 (1.5米)

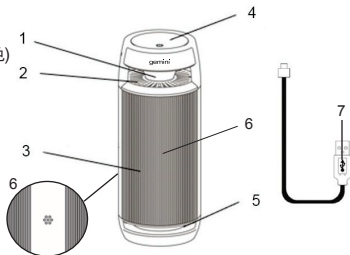

過濾網

(前置過濾網、HEPA高效過濾網及活性炭過濾網)

LED 顯示屏

1. 風速指示燈
 - 1a. 從左到右為初級淨化 (低速)
 - 1b. 快淨化 (中速)
 - 1c. 高效淨化 (高速)
 - 1d. 自動模式
2. 溫度指示燈
3. 濕度指示燈
4. 空氣質量指示燈 (藍/黃/紅)
5. 開/關/淨化空氣風速鍵 (低 - 中 - 高)
6. 現時室內溫度顯示
7. 現時室內濕度顯示

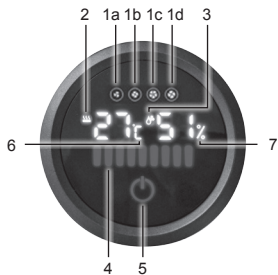

如何使用

- 將USB電源輸出插頭插到本機上，再將USB插到5V電源位置。

自動感應空氣質量模式 (頂部面板)：



- 連接電源，若於2秒內沒有任何操作指示，空氣淨化器會進入自動感應空氣質量模式，最初開/關/淨化空氣風速鍵  默認為藍色，自動探測約2分鐘後，本機會根據室內空氣質量程度自動調整3檔淨化空氣速度（低—中—高）。



藍色（空氣品質優）

黃色（空氣品質較差）

紅色（空氣品質最差）

若空氣品質優，會自行於低工作風速運作。（低速  及自動 ）

若空氣品質較差，會自行於中工作風速運作。（中速  及自動 ）

若空氣品質最差，會自行於高工作風速運作。（高速  及自動 ）



*自動感應空氣質量模式不供自行於輕觸顯屏上調校。本機會於開機後自動感應空氣質量而操作。

手動模式 (頂部面板)：

連接電源，可按頂部開/關/淨化空氣風速鍵  調節風速，

第一次按  為初級淨化（低速 ）；

第二次按  為快速淨化（中速 ）；



第三次按  為高速淨化（高速 ），依次循環。

長按三秒，產品自動關閉

裝飾用的漸變LED燈的開啟和關閉

當連接電源時，彩色漸變燈自動漸變亮起，當長按開/關/淨化空氣風速鍵  約2秒的時候，彩色漸變燈關閉。若需再開啟彩色漸變燈，需要重新開啟本機。

更換高效過濾網

為維持最佳淨化性能，本機工作運轉3-5個月後，根據過濾網的污染程度，產品在運作時會自動提示進行更換過濾網，開/ 關/ 淨化空氣風速鍵  紅色顯示燈閃爍3次，會發出“滴”3聲，此時需要更換過濾網，更換完成後，長按8秒開/ 關/ 淨化空氣風速鍵  開始，顯示綠色閃爍後，本機重啟開始進入正常工作狀態。

更換高效過濾網的方法：

將本產品先關機，

然後順時針方向旋轉本機底部外殼，轉到位後便可鬆開（如圖1）

將中間的高效過濾網取出，然後放入新的過濾網（如圖2）

再逆時針旋轉底部外殼，扭到位便可（如圖3）



圖 1



圖 2



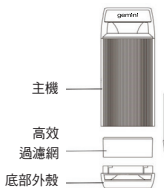

圖 3

清潔及保養

- 切勿用液體清洗或潑灑本機，如水、清洗劑或易燃溶劑等，如需清潔，請請拔掉電源線，使用柔軟抹布擦拭。
- 將本產品放在陰涼乾燥的地方。

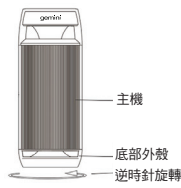
疑難排除

問題	原因	解決方法
本機無法開啟	沒有按開 / 關鍵	按下開 / 關鍵
	異常過高或過低電壓	確認5V電源是否可靠連接
	主電源關上或USB插座鬆開	重新插入主電源插座或檢查USB電線是否鬆開
開 / 關 / 淨化空氣風速鍵  紅色顯示燈閃爍3次，會發出“滴”3聲	需更換過濾網	參考“更換高效過濾網”(第12頁)

產品規格

型號：GAP5B

電源：DC5V 1A

功率：3 瓦

配件：1.5米 USB 電源線

產品尺寸：72 (直徑) x 180 (高) 毫米

請記錄下列產品資料

• 型號

• 機身編號

• 經銷商名稱

• 購買日期

本產品不斷改進中，如功能有所更改，恕不另行通知，如有疑問，請與客戶服務中心聯絡，不便之處，敬請原諒。

說明書內容以英文版本為準

ToolBox Customer Service Centre 客戶服務中心：

4/F, DCH Building, 20 Kai Cheung Road, Kowloon Bay, Hong Kong
香港九龍灣啓祥道20號大昌行集團大廈4樓

Customer Service Hotline 客戶服務熱線：(852) 8210 8210
Service E-mail 電郵地址：8210service@gilman-group.com
Please register now at 請即上網登記：www.toolbox.hk
Website 網址：www.gilman-group.com



Proudly Serviced by:



太平家庭電器